

Conceptual Design

Hugo Corres-Peiretti
José Romo
Javier León
Alejandro Pérez



The objective of this *fib* text is to explain some of the essential arguments which lie behind the resisting aspects of structural concrete.

This chapter aims at providing ideas on how to conceive/create structural solutions for different structural problems, from a global perspective allowing to take advantage of, among others, the knowledge to which reference is made in the other chapters of this text.

The conceptual design of a construction involves the choosing of a certain solution among the many possible which must be studied in order to solve a particular problem. Good projects are characterized by the proposal of outstanding solutions in which it is perfectly clear how the different design conditions of the problem are met: functional requirements, connected to the goal of the structure; structural requirements aimed at meeting, with safety, the different external actions (gravity loads, climatic loads, etc.); environmental requirements, necessary for achieving sustainability, and in consonance with these, durability requirements, that is the satisfaction of the mentioned requisites during the lifetime of the structure. To the previous list, of a mainly technical and economical character, other aspects must be added: aesthetic requirements, of a more subjective nature, which will generally reflect the style of the designer, formed and cultured throughout his professional life; social requirements to which the project must be adapted in order to insure its integration into the medium and culture for which it is designed; innovations which must be sought and introduced, etc.

Conceptual Design

It is very difficult to describe this process explicitly. It is not formally defined and in the best of cases is poorly exposed in Engineering Schools, even though it is absolutely necessary in order to provide sound engineering.

Conceptual Design is an ability which is acquired through time. It requires from the professional engineer a **great effort in understanding the requirements**; it requires an **ample engineering and human culture**, in order to be sensitive to the many variables involved, to all, if possible, which are implied by the act of design; it requires **great ambition**, that which is a trade mark of those who, in any engineering activity, look always for the best of solutions; it requires **experience**, which is nurtured from successes and failures the indispensable heritage needed to build a path of continuous evolution until the last minute of the last project. There are probably other requisites besides those which have been mentioned above, but it is certain that without satisfying these it would be difficult to even make a start.

A project has the magic of starting with a blank piece of paper and a great number of conditions. The first phase generally consists in increasing the number of requisites many of which have not been explicitly established by the client. The best phase is that of brain storming which results in going from the blank piece of paper to many pieces of paper filled with proposals. Since the solution is not unique, any number of solutions is too small. There can always be further proposals. There are always some proposals which are not made explicit. Afterwards, comes the phase of choosing, of decision making, and finally that of refining the chosen solutions. There is always room for improvement. Throughout this process there are no computer models, no fine calculations. There is only imagination, the knowledge acquired through experience and the joy of working. This is how a project is brought into being from the ability to imagine, putting calculations in their proper place, that is, as a tool at the service of creativity which will provide an answer to the challenges laid out.

Afterwards, comes the detailed development of the project always starting from a previously conceived and defined idea. This is the time of detailed verifications.

Conceptual Design

Finally comes the sublime phase of engineering when the ideas are made tangible and real. We engineers have the enormous luck to be able to see, materialized, our ideas, both good and bad.



Figure 1.1 Before design and after construction [1]

Engineers of the past have left us a fabulous legacy, filled with examples which exhibit great ideas, in spite of the very limited technological resources they could count upon when compared to those available today.

The Pantheon of Rome (figure 1.2) is one of the more outstanding examples of building engineering. The inside of the building is inscribed in a perfect sphere of 150 feet of diameter (43.44 m), a record span in concrete construction, only broken at the beginning of the 20th century by Max Berg with the Centennial Room in Breslau. Rebuilt in the 2nd Century by Apollodorus of Damascus (then at the service of Hadrian), its architectonic configuration is adapted to the philosophical conception which related human beings with the vault of heaven, whose center, the oculus, is the sun. This is the theme of the architectural configuration from which was built the most outstanding vestige of roman antiquity, filled with excellent engineers. The counterbalance of the dome is formed by a drum of *opera latericia* (brick) 7 m deep, wisely

Conceptual Design

configured with a grid of arches built into the drum walls which allow it to resist both the compressions transmitted by the meridians of the dome as well as the circumferential tension stresses at the spring of the dome. The dome itself has variable depth, ranging from 5,90 m at the dome springs to 1,5 m at the oculus, masterly distributed with recourse to partial waffle-slab-like voids on the inside and a discrete set of rings on the exterior of the building.

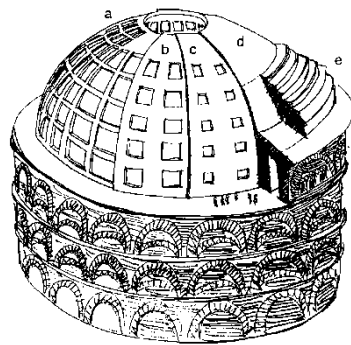
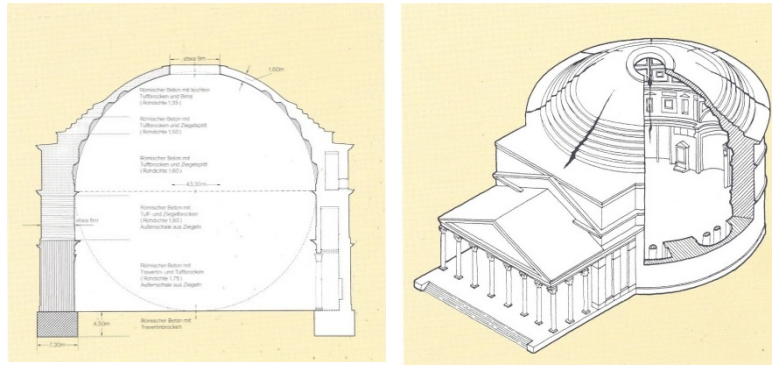

Figure 1.2 Above, constructive sketch of the Patheon of Rome [2]. Below, cross section and axonometric view of the same work [3].

In the field of concrete structures, it is indispensable to recall some of the names and high points which have dominated, in a relatively recent past, the process of innovation in construction and which must be regarded as examples from the pedagogic point of view as this text is meant to be.

Conceptual Design

Emil Mörsh (1872-1950), figure 1.3, pioneer of knowledge, of design and of normalization of concrete structures was, among many other things, the author of the phrase “*nothing is more practical than a good theory*”, which expresses the need for engineers to be well schooled with regard to resistance mechanisms. There is no doubt that a good theoretical and conceptual basis is essential to structural projects.

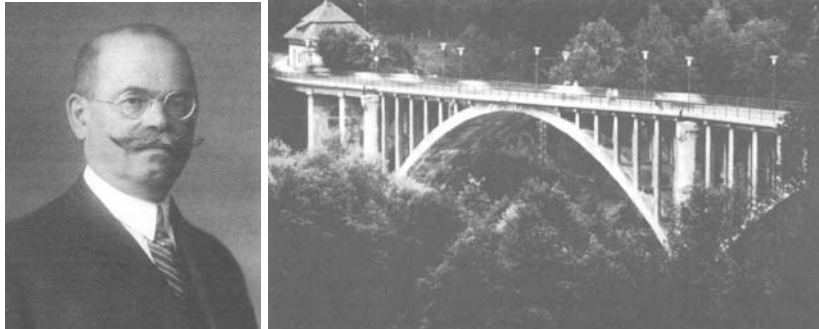
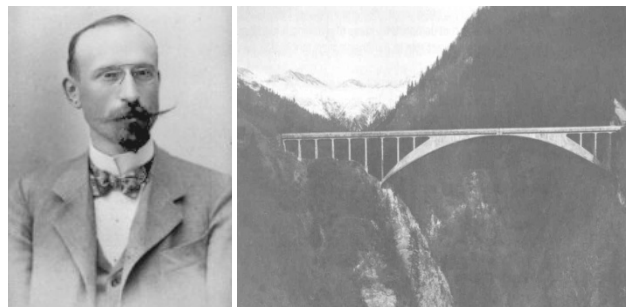
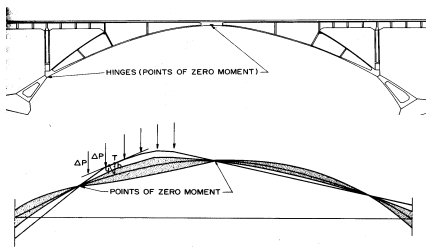
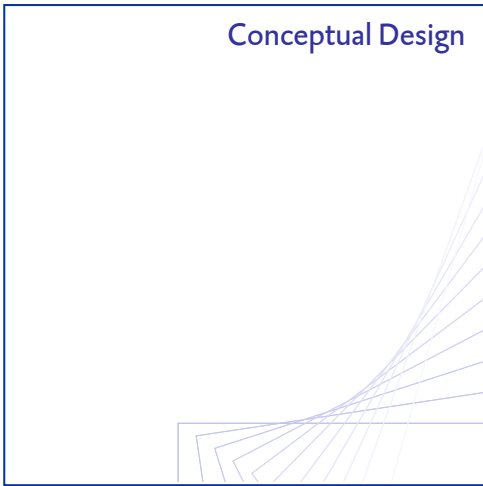

Figure 1.3. Grünwald bridge over the Isar river, the work of a young Mörsh (1904). The bridge has two arches of 70 m of span and 8 m of width. Today this bridge may seem conventional, but in its time, it materialized the consecration of structural concrete as a material which could emulate stone and improve on its structural properties and constructive possibilities. [4]

Robert Maillart (1872-1940), figure 1.4, is one of those brilliant engineers which represents a before and an after in structural engineering. Living a life worthy of the best movie script, Maillart elevated to an art, with its own personality, the design and construction of structural concrete. Faced with phenomena involving complex analytical formulations, Maillart acted as an engineer, rather than as a scientist, by studying the problem by empirical means, investing important sums of money in the building and testing of prototypes which could allow the experimental validation of his design criteria. The experimental techniques, which he developed very personally, with measuring devices which are still used today for load tests, were not only a solid guarantee of his systems but also magnificent proof of his technical competence.



a)



b)

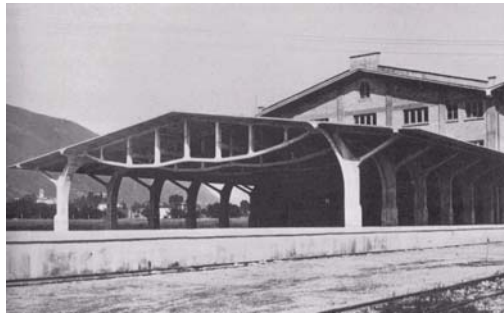

c)

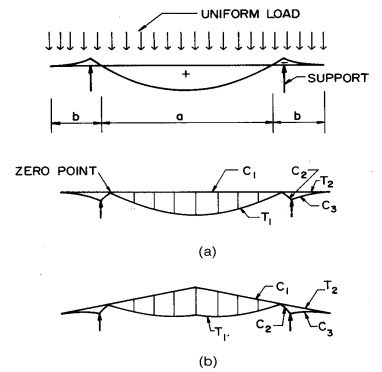

Figure 1.4.a) Salginatobel Bridge (1929). It represents the full maturity of its author in the knowledge of structures, the most efficient use of materials and the play between the stiffness of the deck and that of the arch. Both figures are taken from David P. Billington's delightful book [5]. b) The "slab without beams" of the Giesshübel warehouse, Zurich, 1910, is a concrete slab of constant depth, supported on pillars with capitals. Its practical applications was preceded by an intense and intelligent experimental campaign (1908) which guaranteed both technically and psychologically the invention. c) In the Magazzini Generali in Chiasso (1924), a work of a full creative and intellectual maturity, Maillart amuses himself by proposing a structure with the minimum amount of materials – concrete and steel – which expresses a deep knowledge of the resisting mechanisms of the structure.

Eduardo Torroja (1899-1961) is another of those distinguished figures, which destiny has provided society with, figure 1.6. Torroja, who stood out as designer, researcher, teacher and author of technical codes, made no concessions to improvisation. The ideas that he made known to the outside world were the mature fruit of deep pondering, of the precise enunciation of the problem and its boundary conditions, as well as the study of different possibilities and alternatives.



a)

Conceptual Design

The activity of Torroja comprehends all structural typologies, distinguishing himself in some of them in a specially brilliant and pioneering way. This is the case of laminar structures. Torroja, who was very well formed in mathematics and geometry, put his full talent into the design and construction of such structures as the Algeciras market (1933), the stands of the Zarzuela horse racing track (1935) or the Recoletos Fronton (1936), of a staggering slenderness.

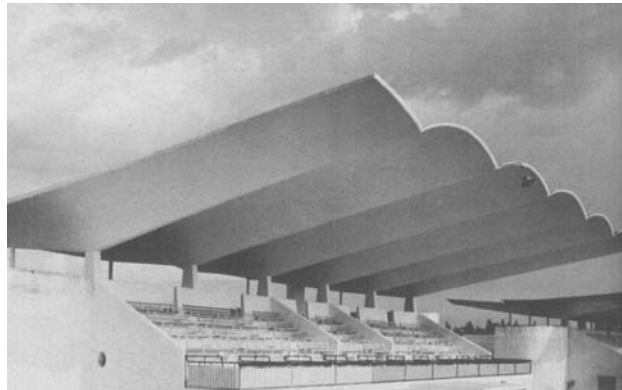

b)
 Figure 1.5. a) Roof of the Algeciras market (1933), with a span of 47,6 m and a depth of 8 cm, a slenderness equivalent to that of an eggshell. Torroja is aware that the success of such a structure is heavily dependent on the effective materialization of the assumed boundary conditions which are achieved by an octagonal ring at the roof springs (including stays which prevent the transfer of horizontal forces to the vertical supports) and by the addition of cantilevers which ensure the effective realization of the sought after membrane state as soon as possible. b) Cover of the stands of the Zarzuela Horse Racing Track (1935). Successive versions of the cross section of the stands and resisting mechanism revealing a wise distribution of mass and stiffness in mutual equilibrium, the result of a deep study of the structural behavior [6]

Eugène Freyssinet (1879-1962) is an epic figure of French and international engineering (figure 1.6). Designer, builder, inventor, businessman and artist, recognized by all, this brilliant engineer, a man of his time, living an intense life, was able to understand the ins and outs of the profession better than others, and has gone down in history as the inventor of prestressing, and as the author of construction techniques which made possible and economic the building of the structures he designed.

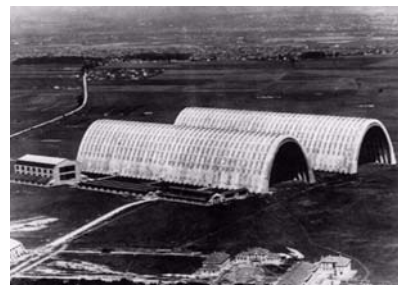

a)

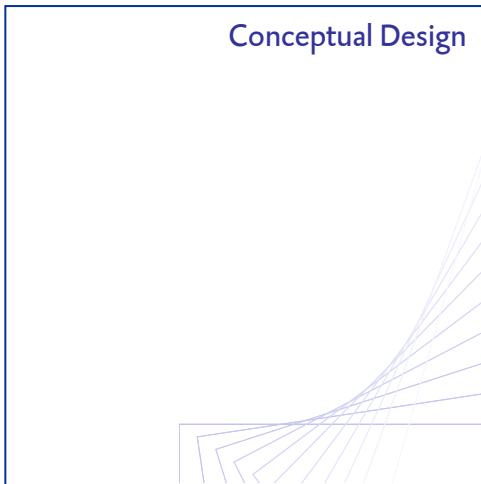

b)

Figure 1.6 a) The Orly hangars(1923). The triumph of the resisting shapes in concrete and of construction techniques with modular formwork. b) Several aspects of the construction of the Plougaster bridge, over the Elorn Estuary in Brittany in inverted order. The key to the construction of the bridge according to Freyssinet's proposal was the construction sequence involving scaffolding transported by flotation [7].

After the above thoughts it must be warned that this text does not aspire to describe in detail the process followed in conceptual design, nor give enough information to guarantee its learning. It only lays out a few ideas, tries to define the problem, illustrate it by lively examples. This is because the creative act is individual, requires the living out of the experience, the conscience of the examples of brilliant designers of structural concrete of the past, and, above all, the existence of a guiding idea. Without this idea there is no project. Without this idea structural engineering is not possible.

1. What is Conceptual Design?

During the last decades, this term has been coined to refer to many concepts which have not yet been clearly defined.

The symposium on Conceptual Design, organized at the University of Stuttgart by Prof. Jörg Schlaich in 1996 [8], was possibly the first event organized by engineers to analyze this problem. It was the result of a long-time felt concern of a few professionals.

The preface to the symposium papers, literally states: *The overall quality of many structures today leaves much to be desired. The*

Conceptual Design

rapid technological progress does not reflect adequately in their variety, beauty and sensitivity. Too often structural engineers neglect the creative conceptual design phase by repeating standard designs and not sufficiently contributing with own ideas to the fruitful collaboration with architects. Engineers thus often waste the chance to create building culture.

The announcement of the symposium invited participants, supposedly expert designers, to describe the process of design, the process of the creation of a solution to a problem. The symposium had a high attendance and was very interesting, but was not conclusive as to the definition of conceptual design, nor as to the definition of the process leading to the final solution.

Conceptual design is a process or design method which, using the available resources – structural, technological, cultural, creative, etc. – aims at making easier the search for the solutions to a project, to a structural problem, etc.

The objective of the process is to find the optimal solution to a multi-variable problem, in which which all variables are important.

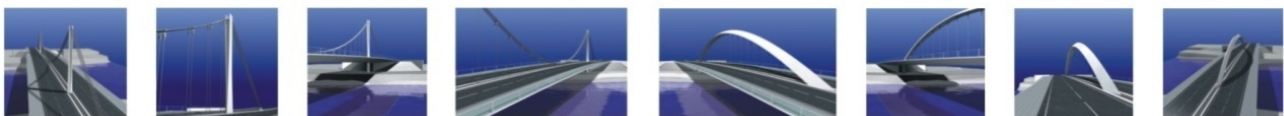
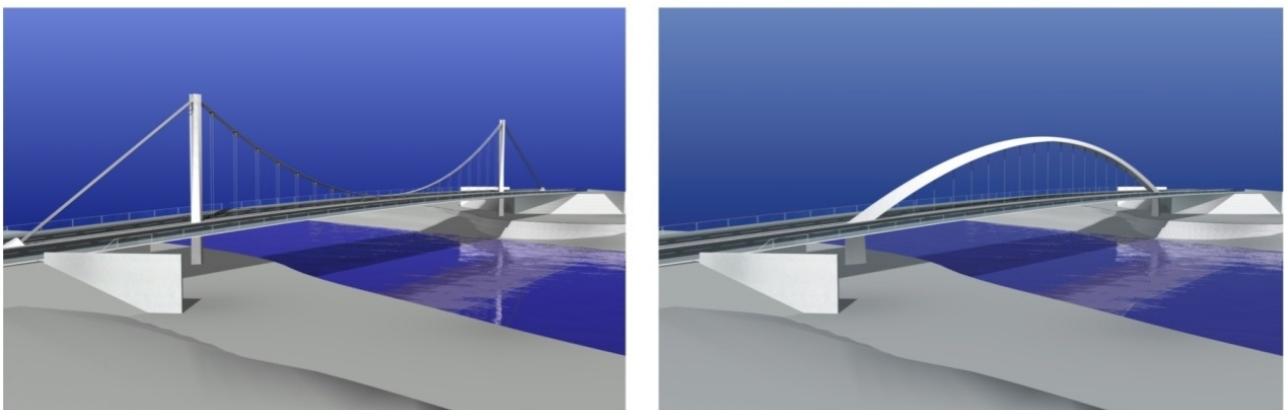

Figure 2.1 Contest of ideas. Proposed solution for a semi-urban bridge in which road traffic, pedestrian traffic on the bridge and pedestrian traffic along the riverbank had to be integrated in a structure which should become a central element in the articulation of the development of this new part of the city. [9]

Conceptual Design

It must be made clear that this process does not guarantee the quality of the idea. An interesting idea, even a brilliant one, does not come from sudden inspiration. It is the result of a persistent search and of detailed and hard work. We have all sometime seen how hard work, the intelligent and unrelenting search, the tenacious persistence in finding by discarding, ends in yielding results. The best results.



Figura 2.2 Concurso de ideas. Evolución de la forma de la pila de hormigón del puente colgante de pequeña luz, 160,00 m. [9]

Conceptual design is a process which can be employed at different levels within a Project, in each case involving different resources, as shown in figure 2.3.



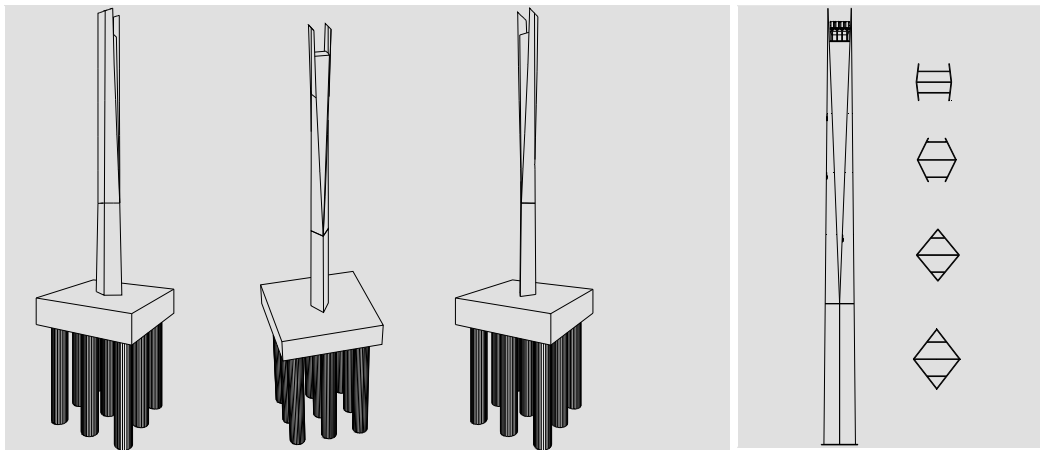
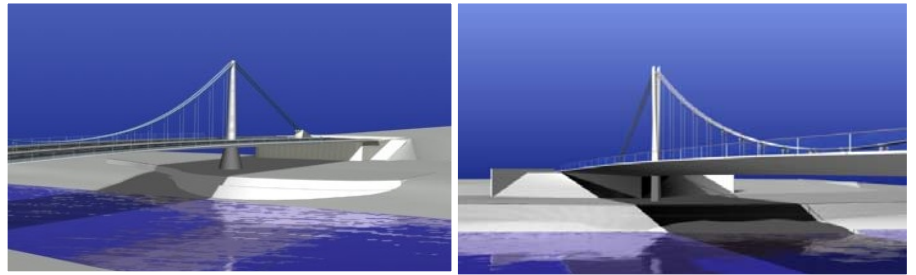
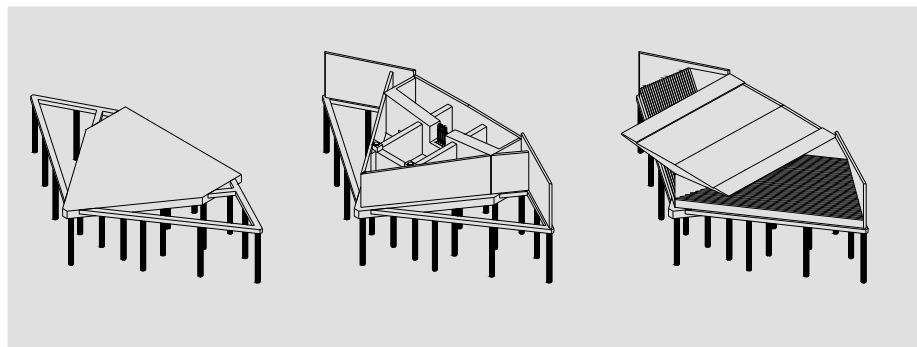
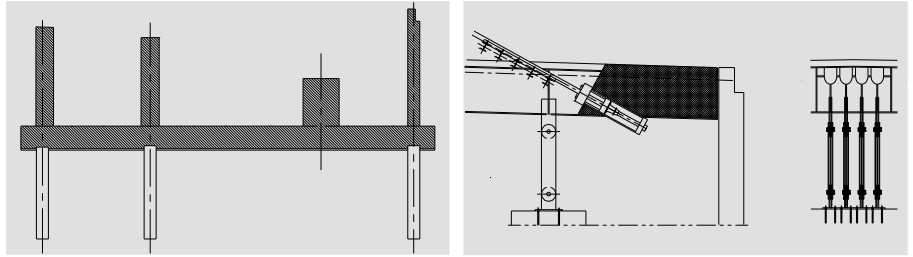
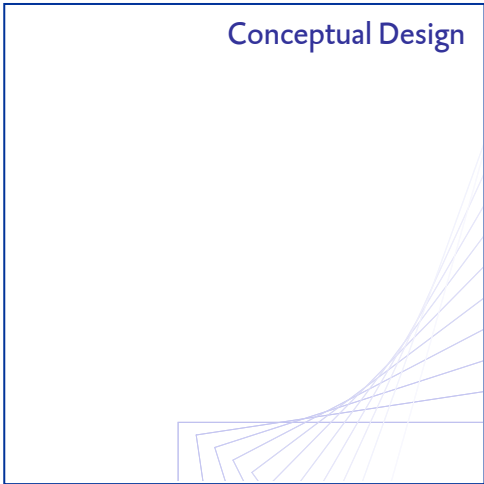
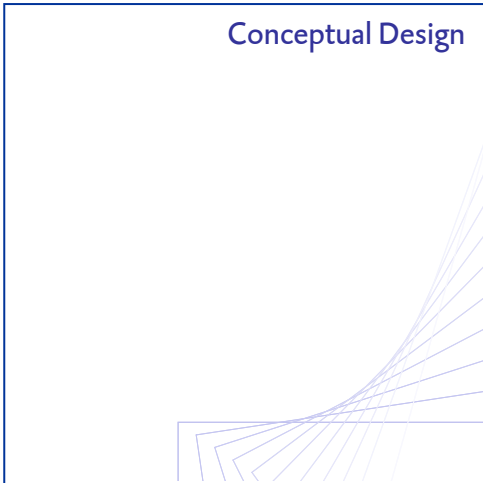

Figure 2.3 Contest of ideas. Study of the anchorage detail of the main cable in the abutment which serves as counterweight. [9]

These ideas are also indispensable in the much needed interventions on existing structures. Far from being a second order activity because of the lack of sparkle of new constructions, this type of work allows to delve into such interesting aspects as the understanding of built works, their historical and construction context, the knowledge of the materials and their degrading mechanisms, which cannot be avoided. They are sources of learning on a scale of one-to-one which can later be used on new structures. It allows to understand, because it becomes self-evident, that constructions have a fourth dimension, that of time. The same ideas of conceptual design can be applied to all these activities, which are comprised in this fascinating field - inspection, diagnosis, therapy and the formulation of a prognosis.



Figure 2.4 Los Santos Bridge [10]. Existing bridge comprising three 150,00 m spans, built by the cantilever method in the 1980's. The bridge deck was widened from 12,0 to 24,0 m by reinforcing the existing box cross section and using new ideas and materials in order to minimize the impact of the additional loads.



The process proposed by Conceptual Design is always applicable. To all activities, from the most general ones to the more detailed ones, even to the most exotic. There can be no engineering without an idea. There can be no project without an idea. There can be no details without an idea.

2. How is Conceptual Design carried out?

It is not easy to define the process of Conceptual design. Figure 3.1 shows a flow diagram which was presented by Jean François Klein [11] at the *fib* meeting SAG 5 New Model Code held at Lausanne, meant to serve as a basis for the introduction of these concepts into the new Model Code.

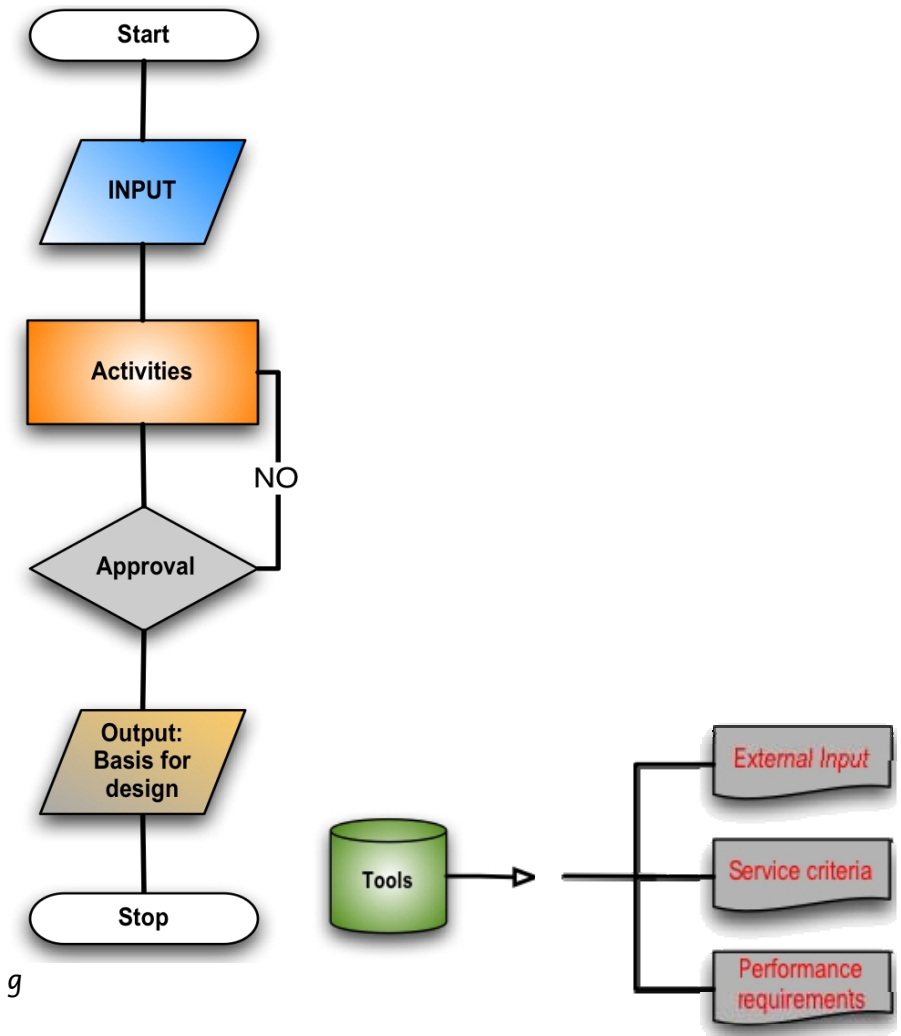

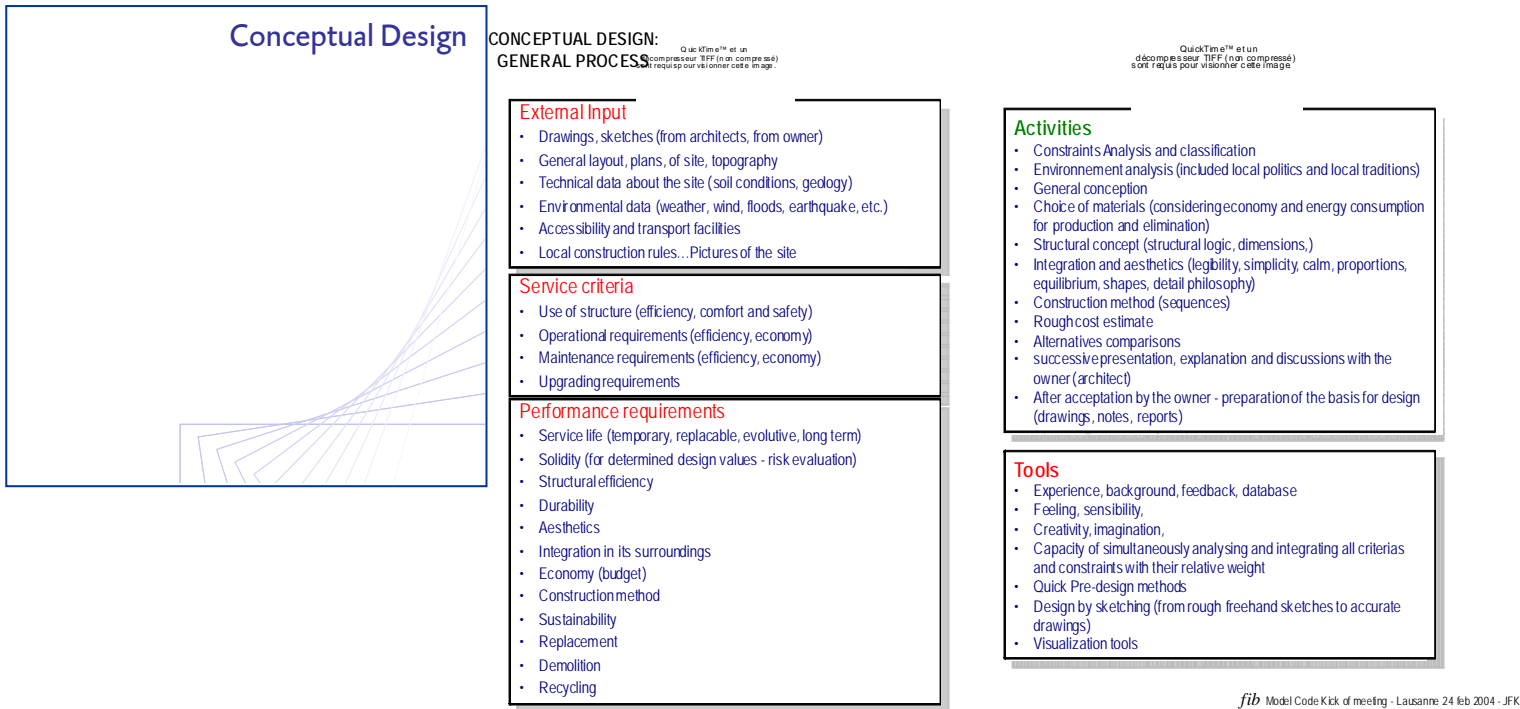

Figure 3.1 Flow chart and tables describing the process of Conceptual Design. [11].

In this paragraph, the process followed for a contest of ideas for the building of a bridge in a semi-urban area is described as a real example experienced.

The conditions of the contest were defined in the competition clauses, which, as is obvious, must be studied in much detail.

It is necessary to visit the site of the future structure. The conditions of the site must be known close-up and personally, it is necessary to talk to the client, in order to obtain additional information, and to talk to the neighbors, if it is an urban work, etc. This is an essential activity. From each visit much information may be gathered. We engineers must be conscious that we must solve problems aimed at improving the life of people, that we are investing public money, and that we need to study deeply all existing conditions. This deeply social dimension, which has always been present in the activity of engineers, cannot be forgotten. This aspect cannot be tarnished by caprice, a topic which although it is a point of acute interest, does not fit into this text.



Figura 3.2 Conditions of the site

It is necessary to understand and study the social and historical conditions of the problem. This means that information needs to be gathered from specialists of other disciplines, such as urban planners, historians. It also means to understand the roots and consequences which the political action of promoting a new infrastructure requires from us as engineers. It is not easy, but it is necessary.

Even though the serviceability criteria and the behaviour requirements are closer to the culture of engineers, and are therefore well considered, it must be kept in mind that such requirements are a few of many others which are equally real and important and are also in need of practical, engineering, consideration.

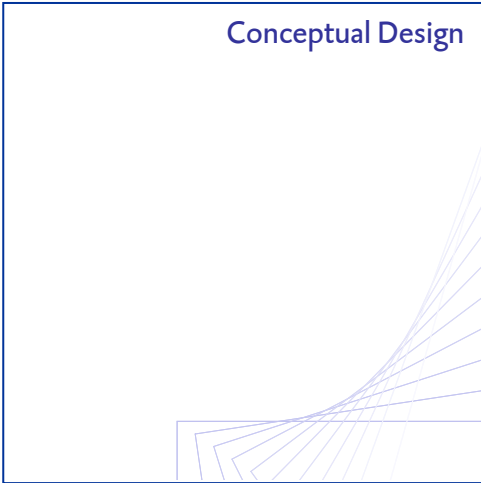
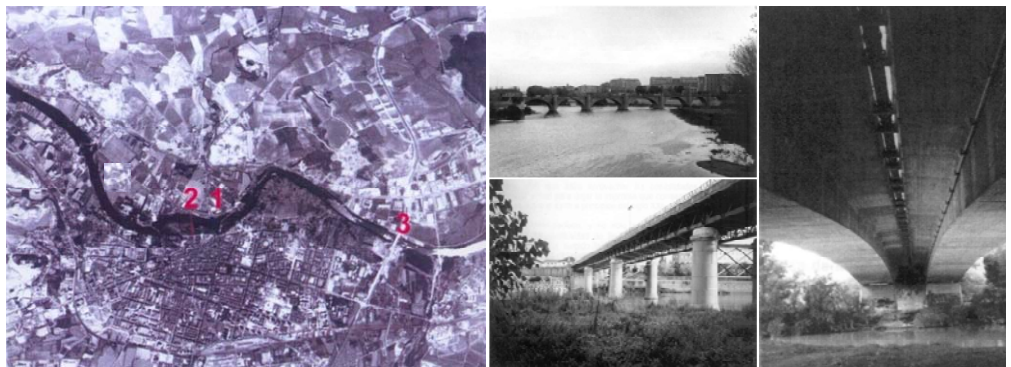

Figure 3.3 Bridges of the city.



Conceptual Design

After this phase, the guiding ideas of the project must be established. These ideas are a synthesis; they are the main ideas of the beginning of the process of approximation to the problem with which Conceptual Design is carried out in order to achieve the optimal solution. In the case of this example the guiding ideas can be summarized as follows:

- ... *It should be a rational intervention, with discretion as a priority, as an integrating quality, and of scrupulous elegance so as to guarantee the acceptance of the work by the users and the city as a whole.*
- ... *The different uses of the work must be optimally integrated in the final solution. Each use must be defined and solved from the beginning of the study to guarantee an adequate solution for each, balanced and compatible with each requirement.*
- ... *The integration of the structure into the landscape must be compatible with the general philosophy of the structure and compatible and in harmony with the general landscape of the town.*

Afterwards, the task of looking for the optimal solution can be launched. The bridge layout in plan, elevation and cross section must be fixed.

In this case, due to the skew of the bridge with respect to the river, a special problem involving the placing of the piers in plan and the design of the abutments was present. Studies were undertaken in order to provide answers to this challenge. A synthesis of this study is shown in figure 4.3.

There are several possibilities. It is possible to use a pier with a single shaft or a pier formed by two shafts. In the latter case, the shafts could be placed parallel to the river, thereby obtaining a skew deck and also, skew abutments, with a clear advantage for the relation between the river and the structure. If, on the other hand, the shafts are placed perpendicularly to the bridge axis, the piers and the abutments would be a larger hydraulic obstacle to the passage of the river.

The solution which was finally accepted was that of a single shaft with triangular abutments. In this way both the problem of skew and the problem of hydraulic interaction between river and infrastructure met adequate solutions. This unedited solution has also allowed the solving of other problems as will be presently shown.

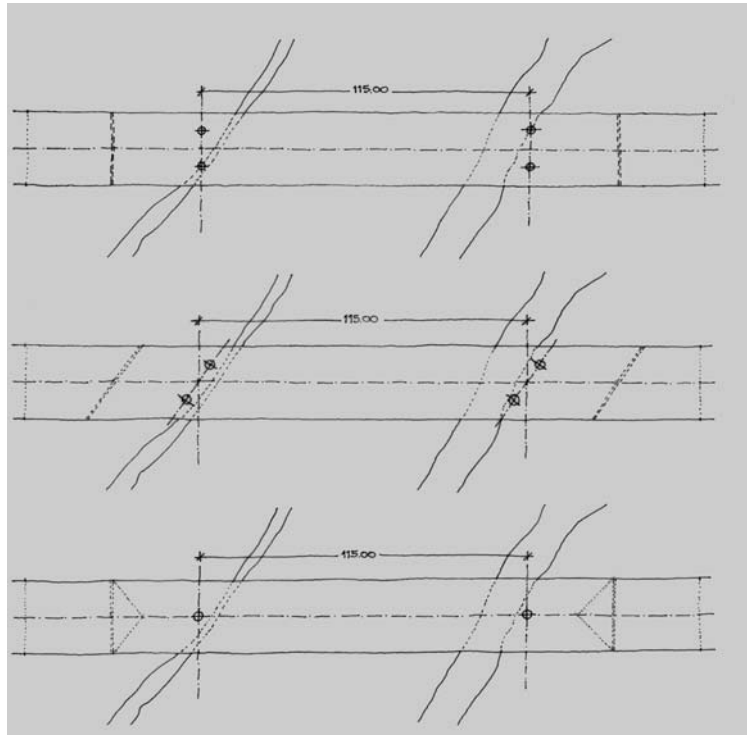
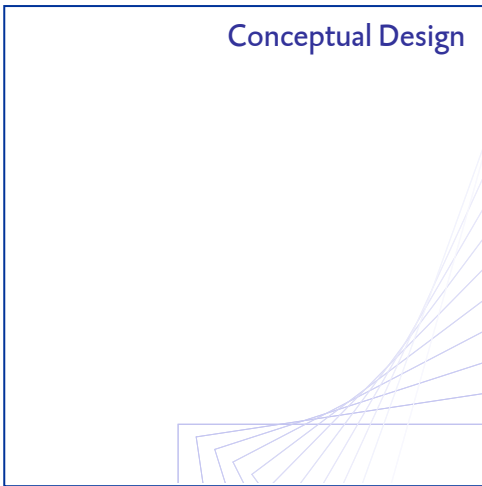

Figure 3.4 Study of alternatives for piers and abutments.

For the definition of the layout in elevation, many possibilities were studied. Generally in a work such as this one, the maximum number of possibilities should be studied. The better solutions will come out strengthened and will provide continuity to the search, while the less optimal solutions will point to new ideas and this is what makes their consideration essential.

These are still paper and pencil activities in which drawing is the most important language of expression, unfortunately not replaceable by the computer. It is not yet the time for 3-D renderings. The scale of the problem must first be felt and control of the created object be attained.

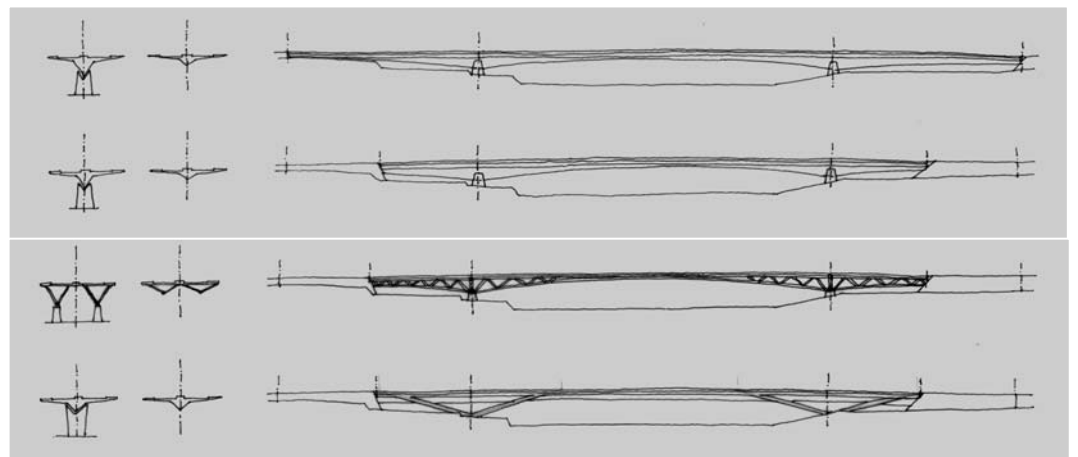

Figure 3.5 Layout study in elevation, with resisting structure placed under the road.

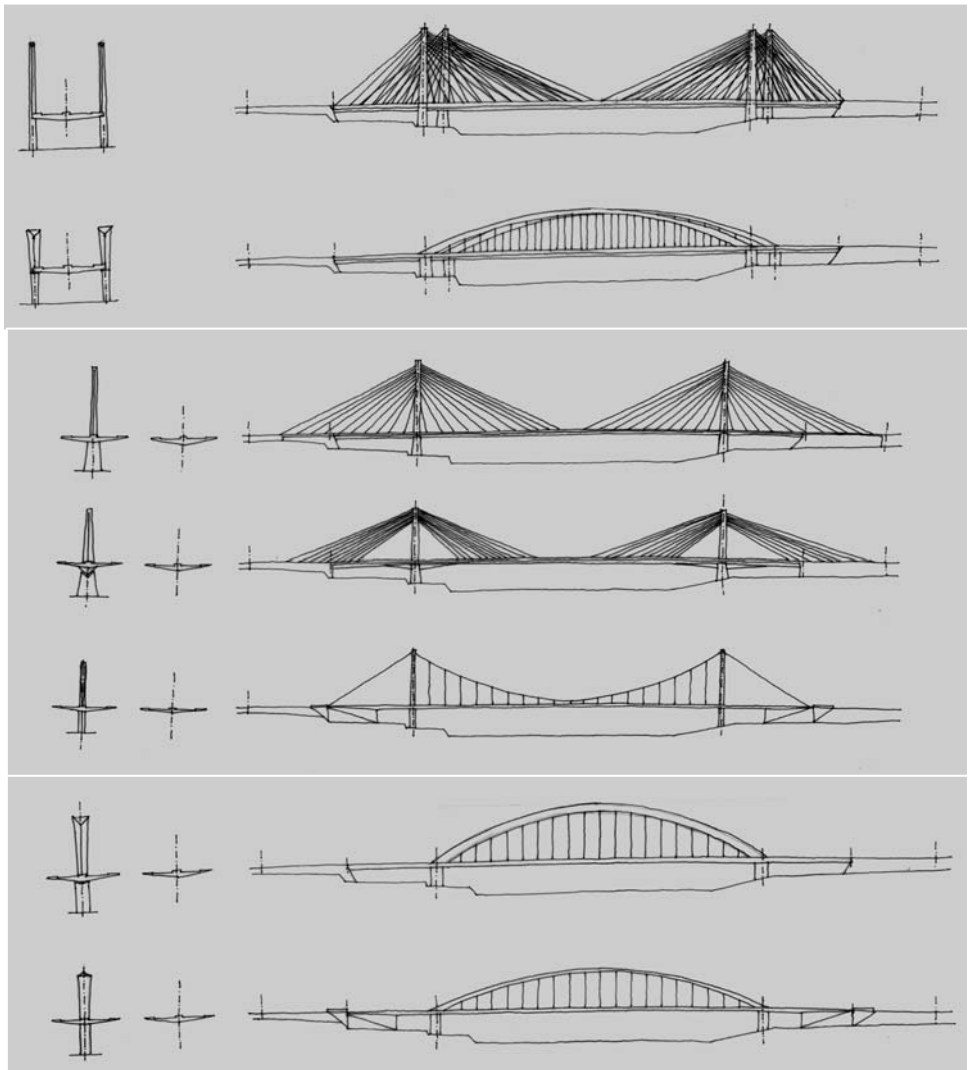
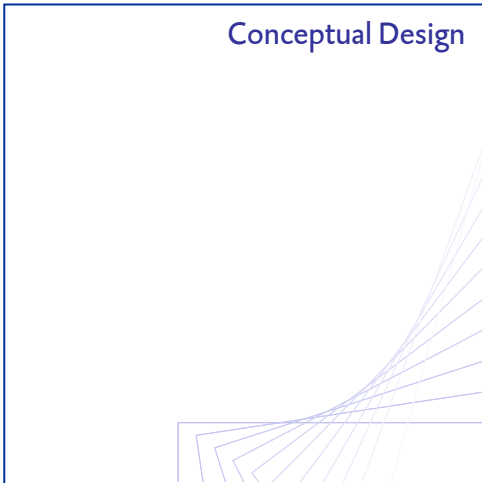

Figure 3.6 Layout study in elevation, with resisting structure placed over the road.

In this phase it was decided to keep two alternatives: an arch solution and a suspended solution, both with a resisting structure placed over the deck and with a single resisting plane.

This was the moment when the first virtual representations were made, before the choosing of the final solution. Figure 3.7 shows the first renderings. It can be seen, that the solutions are still in a very primitive stage. These solutions were yet to undergo much improvement.

Conceptual Design

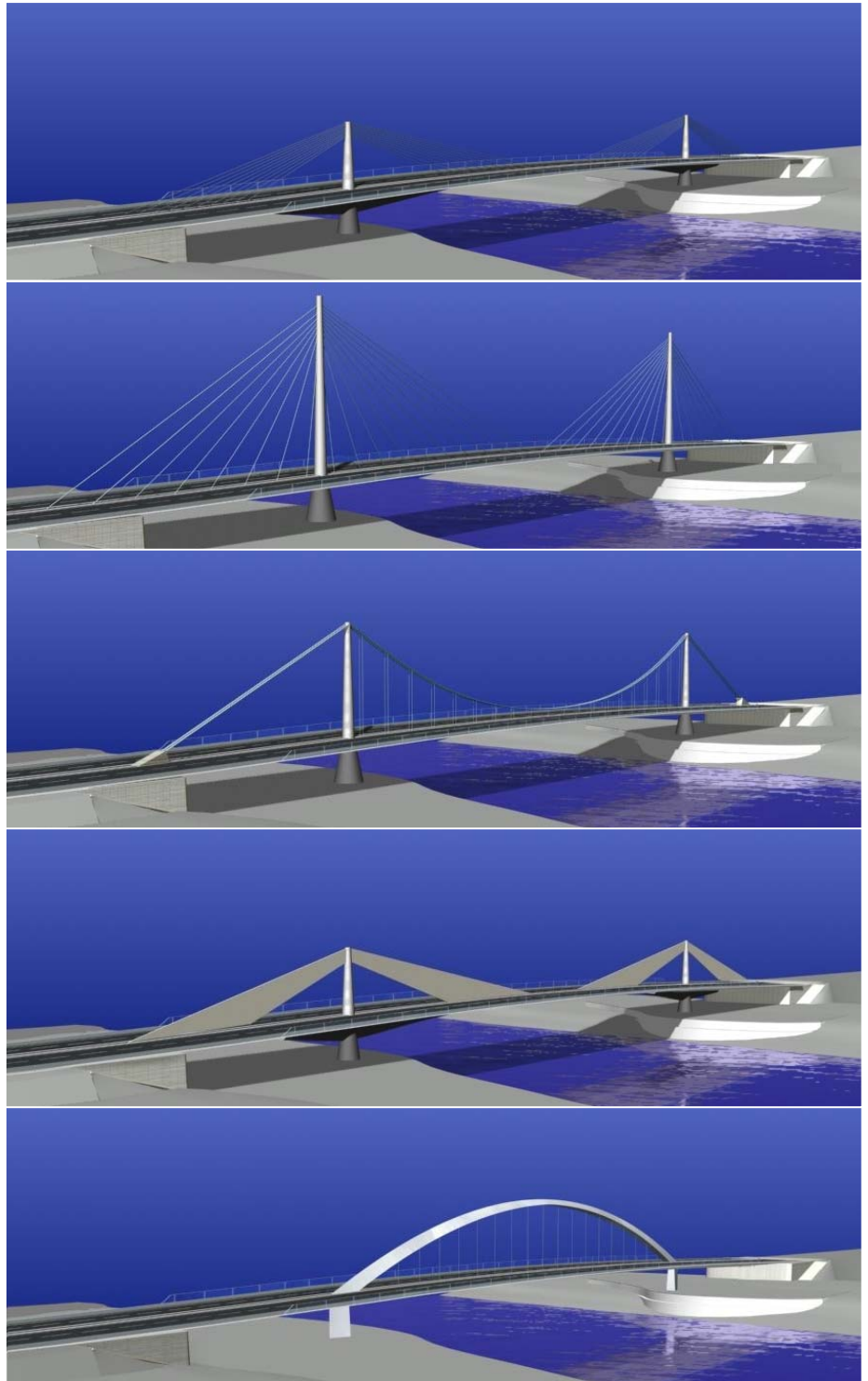
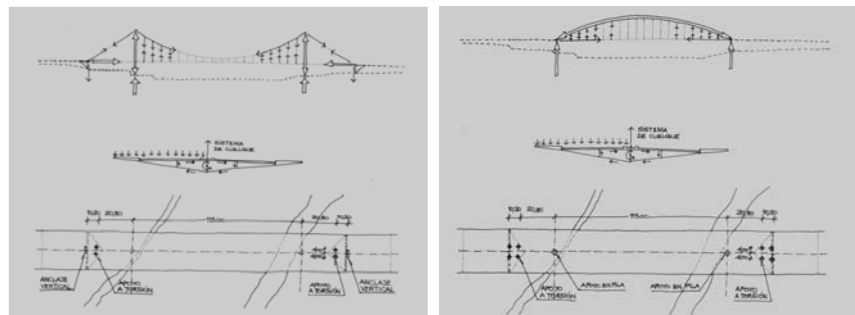

Figure 3.7 3-D Studies of the most adequate solutions aimed at choosing the best path to follow.

Work must continue. The act of creation requires self-criticism and ambition. The details must be deeply studied. All ideas must be tried. Until the last minute the best idea, the best proposal must be sought.

Conceptual Design

Figure 3.8 shows the final structural layout adopted, which must be consistent, they must show clear evidence of our culture as engineers. Figure 3.9, shows the construction sequences which were proposed. Figure 3.10 shows the details of the different structural elements. This type of study is among the most important since it allows refining the proposal up to a degree of detail which good engineering should always achieve. Finally, in figure 3.11, the color studies aimed at deciding the colors to be used in the different elements of the bridge are shown. Different color ranges have been chosen and for each color range a different colors have been proposed for each structural element. Additionally a work of modern art featuring the same shades is shown in order to convey an idea of the combination possibilities laid out.



A

B

Figure 3.8 Structural layout A Suspended solution with composite deck. B Bow-string type

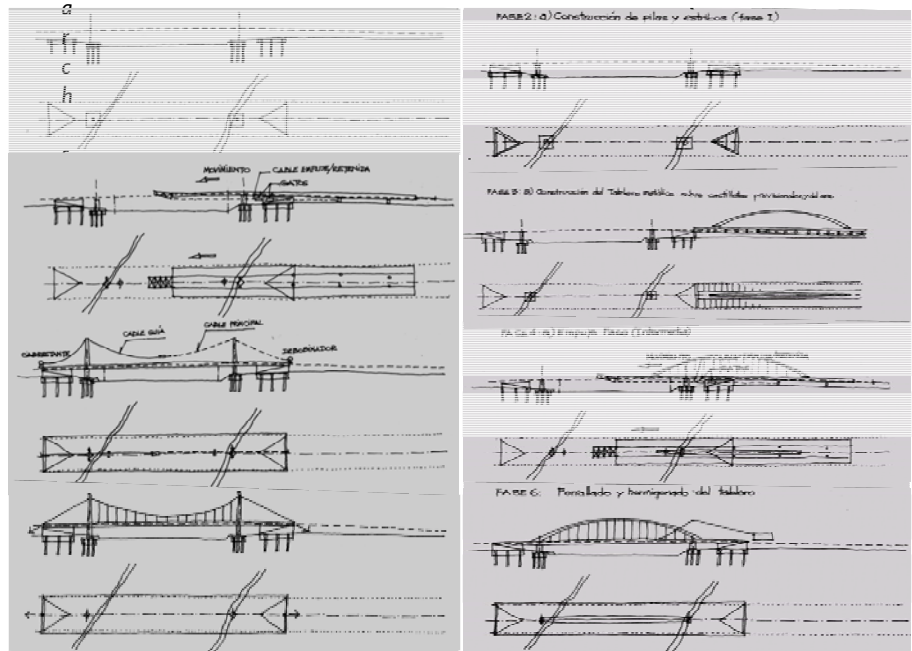

A

B

Figure 3.9 Construction process. a) Suspended solution with composite deck. b) Bow-string type arch solution.

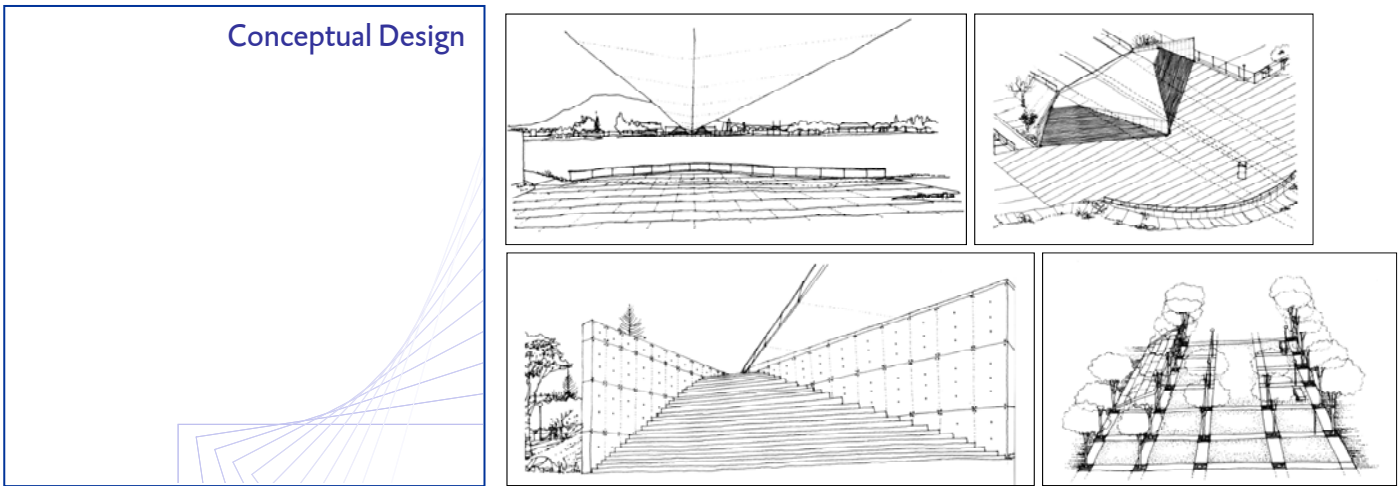





Figure 3.10 Details of different elements of the proposed solutions.

Propuesta *Flavus*: Gama melódica de amarillos

	Estribos	Tablero	Pilas	Cables	Barandillas	Aceras
Color	Amarillo ocre	Amarillo ocre	Amarillo ocre	Gris metal	Oro	Amarillo ocre
RAL	S0510-Y30R	S0510-Y30R	S0510-Y30R		S0585-Y20R	S0510-Y30R

Propuesta *Coerulus*: Gama melódica de azules

	Estribos	Tablero	Pilas	Cables	Barandillas	Aceras
Color	Azul violáceo	Azul ultramar	Gris 50%	Gris metal	Azul cobalto	Gris 50%
RAL	S7010-R90B	S3560-R80B	S3502-G		S4050-R90B	S3502-G

Figure 3.11 Color study featuring two shade ranges

This phase of conceptual design allows defining the idea of the project. It requires the utmost dedication and the greatest attention. It should not be thought resolved with the first idea. It requires the time deserved by good engineering; that needed to

 A graphic titled "Conceptual Design" showing a series of overlapping, slightly offset rectangular shapes that create a sense of depth and movement, resembling a stack of papers or a series of steps. The shapes are light blue and white, with the text "Conceptual Design" in blue at the top left.

Conceptual Design

review, to permanently question a solution and extract from it with the chisel of self-criticism the best piece.

It must not be thought that this is only done when time is available. The time of other activities must be curbed in order to provide time to this most important activity. A good idea always gives rise to a good project. A project without ideas is always a vulgar and a poor project.

3. Some good examples of Conceptual Design

There have been, as anticipated, many good examples of creativity, innovation and know-how in many of the works of the great masters of structural engineering, in general, and built of concrete in particular. Unfortunately, and in spite of the great opportunities we have had in the recent past to engineer, when the great investments in infrastructures have given work to everybody, there have been only few examples of creative, innovative and interesting structural engineering.

There is no detailed documentation of the way in which the process of Conceptual Design has been carried out in all the engineering masterworks of structural concrete of the past. This being, as has been expressed a very personal process, it is not easy to explain in the works of others.

In spite of this, two works of the already mentioned Eduardo Torroja, teacher, researcher and designer, a rare species, whose creative process fits in perfectly well with the *modus operandi* described above, will be discussed.

When he was 26 years old, Torroja faced the need to solve the problem of the design and construction of the Tempul aqueduct (1925). Figure 4.1 shows on the top the original project, and aqueduct with simply supported spans and two piers placed within the river bed, and at the bottom, the solution which was built in which these piers have been replaced by cable stays.

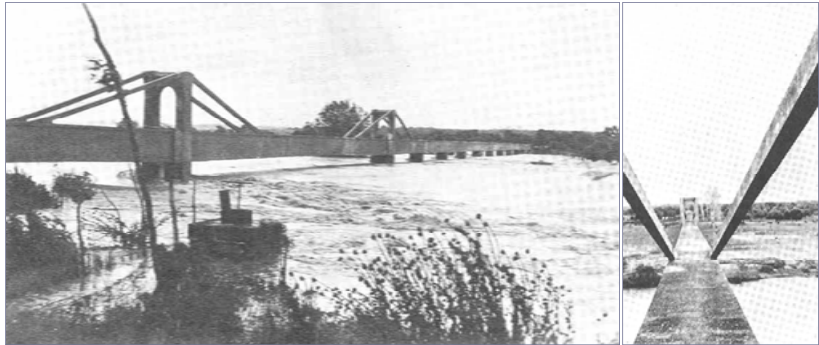
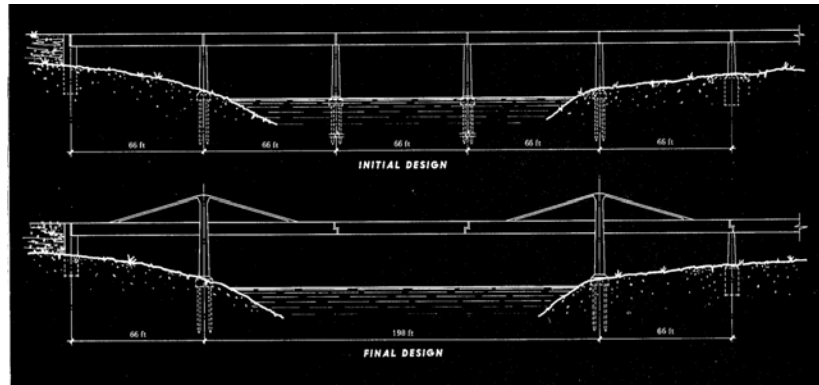
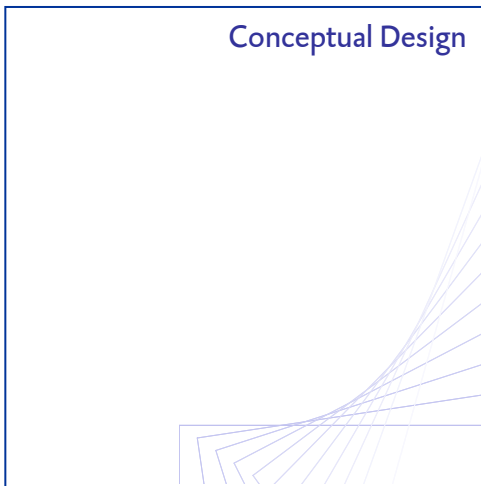

Figure 4.1 Tempul Aqueduct, 1925 [6]

At the time of construction, there was no commercial technology for the stays designed by Torroja. He proposed to use closed cables, of common use in harbors, and in order to stress the stays he proposed to use jacks acting in the vertical direction on the pier tops, as shown in figure 4.2. Also, in order to improve the behavior conditions of the stays, the stressing operation was done with the stays already in tension, supporting the stretch of the U shaped beams going from the pier to the expansion joints. In this situation the stays were enveloped in concrete thereby conferring greater stiffness, greater protection and better durability conditions.

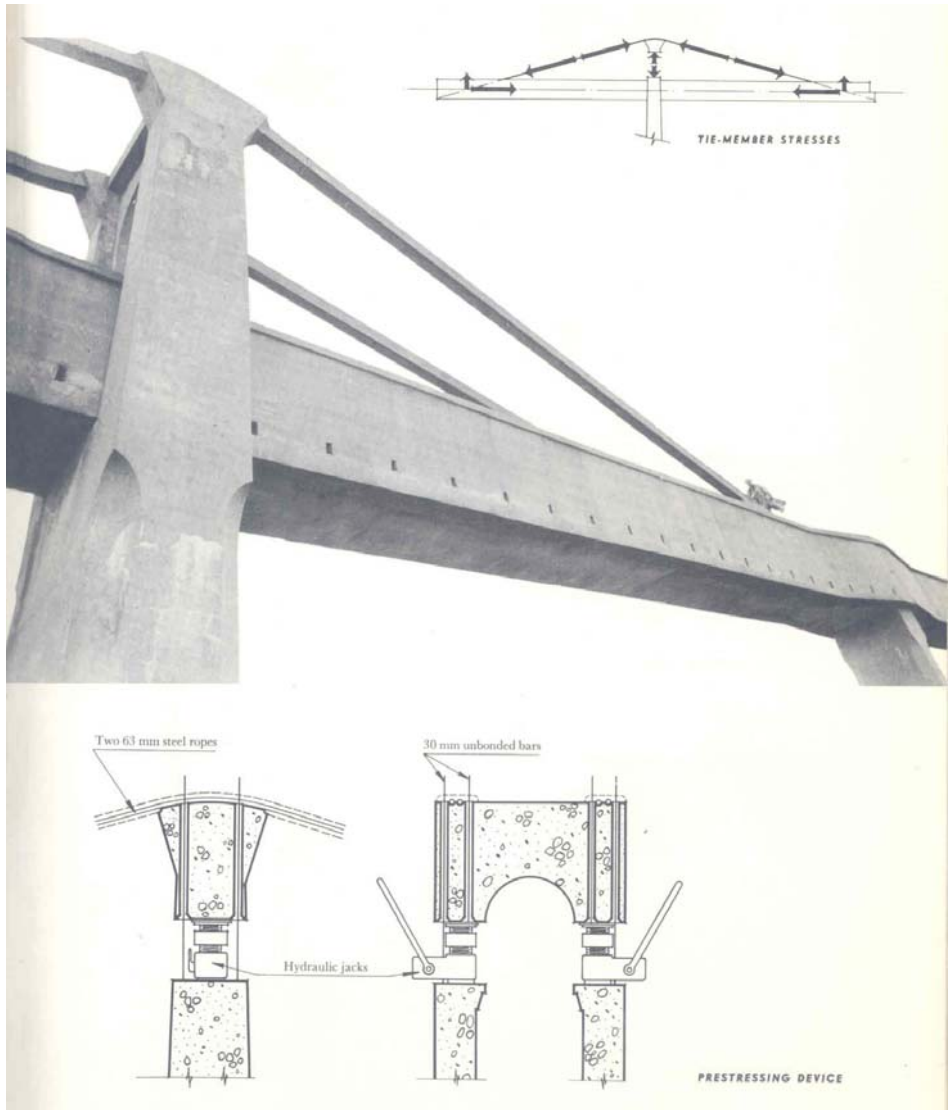
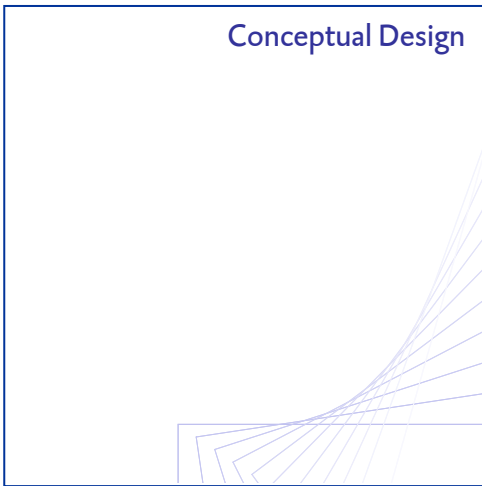
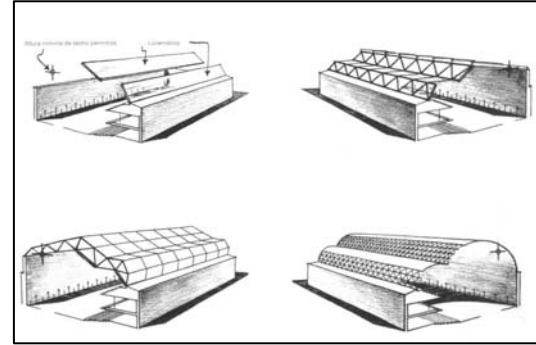
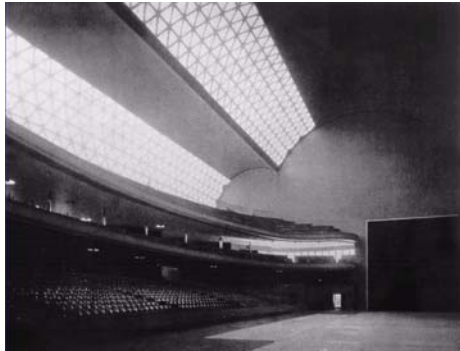

Figure 4.2 Detail of the stressing of the stays [6]

In this example it can be clearly seen how the conceptual solution to the problem, that is the use of stays in order to suppress the piers in the riverbed, is combined with many other ideas aimed at solving the practical problem of stressing and materializing the stays. To this, add that, although many Torroja worshippers saw in this solution a predecessor of prestressing, by the compression produced in the deck due to the horizontal component of the stay forces, the great engineer politely declined the honor, and acknowledged his contemporary colleague Freyssinet, by saying that he had not deliberately sought to produce a previous and favorable tensional state, as a prestressing concept, but had only solved a construction problem. Great figures, often are, thus, humble.

Conceptual Design

One of the most interesting works of Torroja is the Recoletos Fronton, built in 1936 and sadly destroyed shortly after the Spanish Civil War as a consequence of the impacts it suffered. This work, like many others which he designed, is the result of a close collaboration with architects and engineers. Generally, good engineers can be good conveyors of good architecture. This is the case, in the past of Torroja, admired by such great architects as Wright, Pier Luigi Nervi, Peter Rice, etc, and can also be the case in the future.



e

4.3 Interior view of the Fronton Recoletos and images of the typological study made for its conception [6]

In this case, the building requires a playing court, stands, and spaces for different functions of the building. Torroja conceived a longitudinal beam supported by the lateral walls, with a transverse cross section involving two circular curves of 6,40 and 12,2 m of radius, with 0,08 m of depth. The slab was substituted by a concrete grid in certain areas in order to allow the entrance of light. Among the possible solutions, which are also shown in figure 4.3, Torroja adopted the most peculiar, innovative and beautiful. A choice made, after the search, with ambition.

In the brief and dense preface of “Reason and Being of Structural Types” [12], Torroja wrote: *Each material has a specific and distinguishing personality, and each form imposes a different stress phenomenon. The natural solution to a problem – art without artifice –, optimum in the face of the previous impositions which originated it, is impressive by its message, satisfying at the same time, the demands of the technician and of the artist. The birth of a structural ensemble, the result of a creative process, escapes the sole domain of logic and penetrates the secret frontiers of inspiration. Before, and above all calculation there is the idea, which shapes the material in a resisting form, in order to comply with its mission.*

 Conceptual Design

The image shows a graphic with the text 'Conceptual Design' in the top left corner. Below the text, there are several overlapping, semi-transparent rectangular shapes that appear to be part of a larger, abstract design or a series of frames. The shapes are arranged in a way that suggests a sense of depth and movement, possibly representing the iterative nature of conceptual design.

The authors do not believe that there is a better way to describe and synthesize what the process of Conceptual Design is.

4. Strengths and weaknesses of present structural engineering and their relationship to Conceptual Design

Today's situation is sprinkled with so many paradoxes that, at times, it seems unintelligible. We have at our disposal modern design codes, which are the synthesis of our more recent knowledge, powerful and versatile means of calculation, new materials, which are not so well known, fruit of technological progress (probably because the capacity of amazement of post-modern man has decreased), very powerful means of construction, never before seen, and, in spite of it all, the result of structural engineering is not always up to the standards which correspond to such favorable circumstances. Possible the following factors can explain this situation.

The education of engineers, no doubt, an essential factor, has suffered great changes in recent times. It is clear, on the one hand, that the University must provide solid and deep theoretical knowledge, which the engineer must be in possession of, but it should also provide a wide vision of engineering and culture. As is known, and with very few exceptions, the contribution of the University to the humanist education of engineers has become almost non-existent. On the other hand, it is necessary to learn the trade of the structural engineer, which is not acquired at the University, but rather by professional experience. This requires having knowledgeable senior colleagues which serve as teachers for the younger engineers at their working post, which should be pampered, from which young engineers must learn and to which the young engineers must, one day, succeed. Unfortunately this process is not taken care of presently and this is a deplorable waste.

Knowledge has advanced and has become atomized. Too frequently we find that there is no connection, no bridge between the knowledge which is being generated and professional practice. It is patent that the world of research is far away from the world of design, the languages are different and they serve interests which are not common, or even clearly divergent, without points of contact.

 Conceptual Design

The graphic shows a series of overlapping, slightly offset rectangular outlines that create a sense of depth and movement, resembling a stylized architectural or design process. The lines are thin and light blue, set against a white background.

Codes, which have evolved remarkably, can be, in many occasions, an obstacle to invention. They should be written to provide liberty, not to establish restrictions. In this sense, the growingly performance and client oriented character of modern codes contributes to encourage progress which can be contributed to by those who are better prepared, those who have the better control of the art of Conceptual Design.

The computer resources, which at first glance are a significant step forward, can in fact become traps which imprison the minds of engineers, which can only see through the limited and distorted windows offered by mere modeling, which restrict the act of thinking, which confuse designers, now young, which take as sources of inspiration what are mere working tools conceived to free them from the routine of computation.

Reality is rich and complex. Engineering has always distinguished itself by the capacity to manage uncertainty (in words of our dear colleague Javier Rui-Wamba) and it is clear that computer programs cannot solve the uncertainties we face. For that, it is necessary to be conscious of what these uncertainties are. Today it is frequent to see an engineering of *Technicolor*, supported by the post processing of computer programs, in which complex models offer the false hope of solving that which is not known, something which cannot be done, which is not possible. Only knowledge can allow identifying the limits of ideas, and therefore the limits of computer programs. It is essential to know what can be expected from models, it is essential that, at all times, the intellectual fruit, the idea which comes from the process of Conceptual Design prevails, and that computational models be at the service of this idea, helping to quantify them in a more coherent and rigorous manner.

New technologies must be controlled by designers, at least to a sufficient level as to guarantee a sufficient mastery over them. New materials, new gadgets, new technological inventions must be assimilated by designers in order to guarantee their optimal use. Many times, the products which are offered in the world of civil engineering have been developed for other applications and only a sufficient knowledge can allow engineers to use them efficiently.



Conceptual Design

Finally, knowledge, today, requires teams, because it has become so vast that it cannot fit into the minds of individual figures which were all in a past not so far away, but who could not today seize it all with the required degree of detail. This requires a new culture of working together for a common objective: engineering.

5. Final remarks

Design is an art which must be cultivated, it is an act of creation, for which Conceptual Design is an indispensable instrument.

Design is an art which is learned with time, each project is an opportunity which cannot be wasted. Brilliant ideas are not always achieved, but ideas are essential, if they are good it is magnificent y they are brilliant it is an exception.

The development of technology, materials, construction means, etc., is an offer of good possibilities for potential creators.

Bibliographical References

- [1] Corres, H.; Pérez, A. Puente Arco Sobre el Embalse del Burguillo (Avila). 1er Congreso de la Asociación Científico-Técnica de Hormigón Estructural (ache). 1999
- [2] Heinle, Erwin; Schlaich, Jörg: Kuppeln aller Zeiten, aller Kulturen, Stuttgart 1996.
- [3]
- [4] **Morch**
- [5] Billington, David P. "Robert Maillart's Bridges: The Art of Engineering". Princeton University Press. 1989.
- [6] Torroja E. "The Structures of Eduardo Torroja". Foreword by Mario Salvadori. 1958.
- [7] **Freysinet**
- [8] Proceedings of the Conceptual Design of Structures. IASS International Symposium organized by the University of Stuttgart. October 7 – 11. 1996.
- [9] Corres, H., Il Rapporto tra Ingegneria e Architettura nella Progettazione Strutturale. Alcune Esperienze. Architettura Strutturale. Galileo n° 178, pp 12-20. Italia octubre-diciembre 2006.

- [10] Corres, H.; Pérez, A.; Romo, J.; León, J.; Prieto, F.; Sánchez, J.; Sisi, D.; Espeche, A. “The Widening of Los Santos Bridge. A Case Study of a Tailor-Made Structure”. International fib Symposium 2008. Ámsterdam 19 al 22 Mayo de 2008.
- [11] Jean Franceasus Klein. *fib*, SAG 5 New Model Code de Lausanne
- [12] Torroja, E. “Razón y ser de los tipos estructurales”. 1960